



US 20020060200A1

(19) **United States**

(12) **Patent Application Publication**

(10) **Pub. No.: US 2002/0060200 A1**

**Shu et al.**

(43) **Pub. Date:**

**May 23, 2002**

(54) **REDUNDANTLY CONSTRAINED LAMINAR STRUCTURE AS WEAK-LINK MECHANISMS**

(52) **U.S. Cl.** ..... 216/41; 428/571; 428/638

(75) Inventors: **Deming Shu**, Darien, IL (US); **Thomas S. Toellner**, Chicago, IL (US); **E. Ercan Alp**, Naperville, IL (US)

(57) **ABSTRACT**

Correspondence Address:

**Joan Pennington**

**535 North Michigan Avenue Unit # 1804  
Chicago, IL 60611 (US)**

Redundantly constrained laminar structures as weak-link mechanisms and a novel method for manufacturing the redundantly constrained laminar structures as weak-link mechanisms are provided. The method for producing the redundantly constrained laminar structures as weak-link mechanisms is carried out by lithographic techniques. A designed pattern is repeatedly chemically etched with a mask to produce a plurality of individual identical units. The units are stacked together to form the laminar structure and are secured together with fasteners. A high quality adhesive can be applied to the sides of the laminar structure to provide the mechanism equivalent to a single piece mechanism. The redundantly constrained laminar structures as weak-link mechanisms of the invention include a stack of a plurality of thin material structures. The stack of structures forming a laminar structure include multiple weak-link connections providing controllable movements in a plane of the layer and having a desired stiffness and stability. The plurality of thin material structures include predetermined locating-holes used with locating-pins to precisely stack the thin material structures together and are used with fasteners to secure the stack together.

(73) Assignee: **THE UNIVERSITY OF CHICAGO**

(21) Appl. No.: **09/930,699**

(22) Filed: **Aug. 15, 2001**

**Related U.S. Application Data**

(63) Non-provisional of provisional application No. 60/239,599, filed on Oct. 11, 2000.

**Publication Classification**

(51) **Int. Cl.<sup>7</sup>** ..... **B32B 3/10**

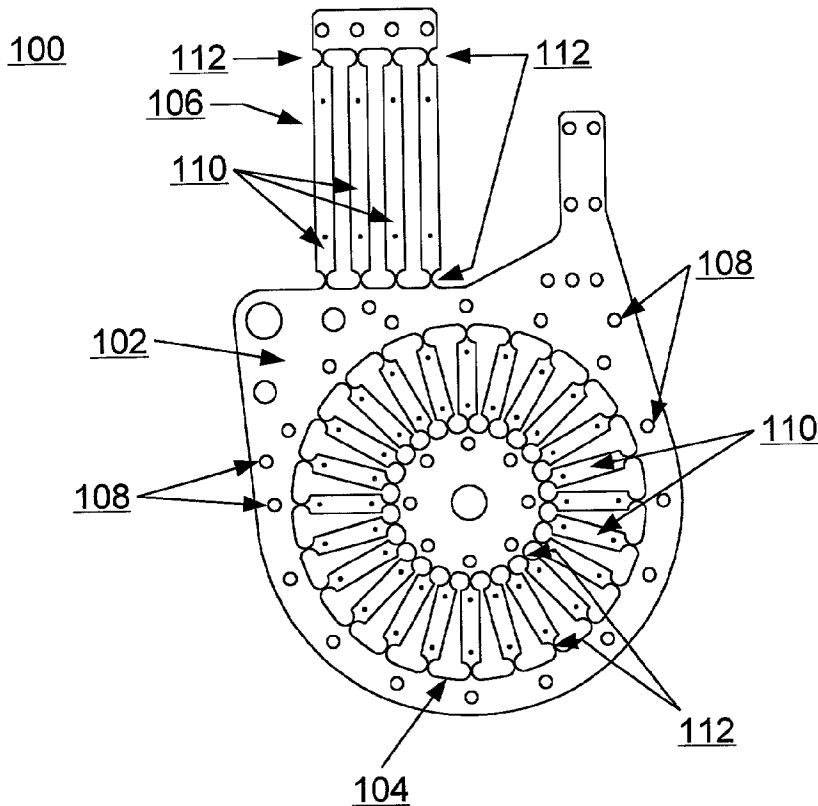

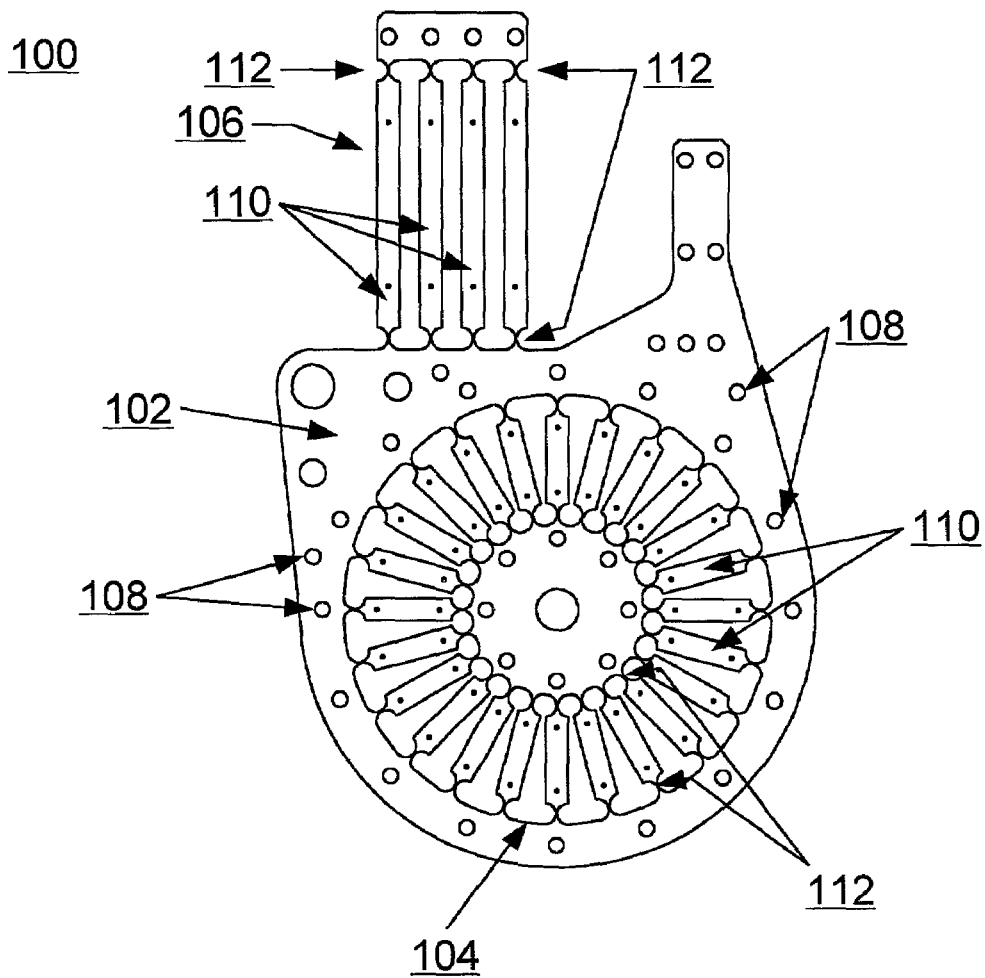

**FIG. 1**

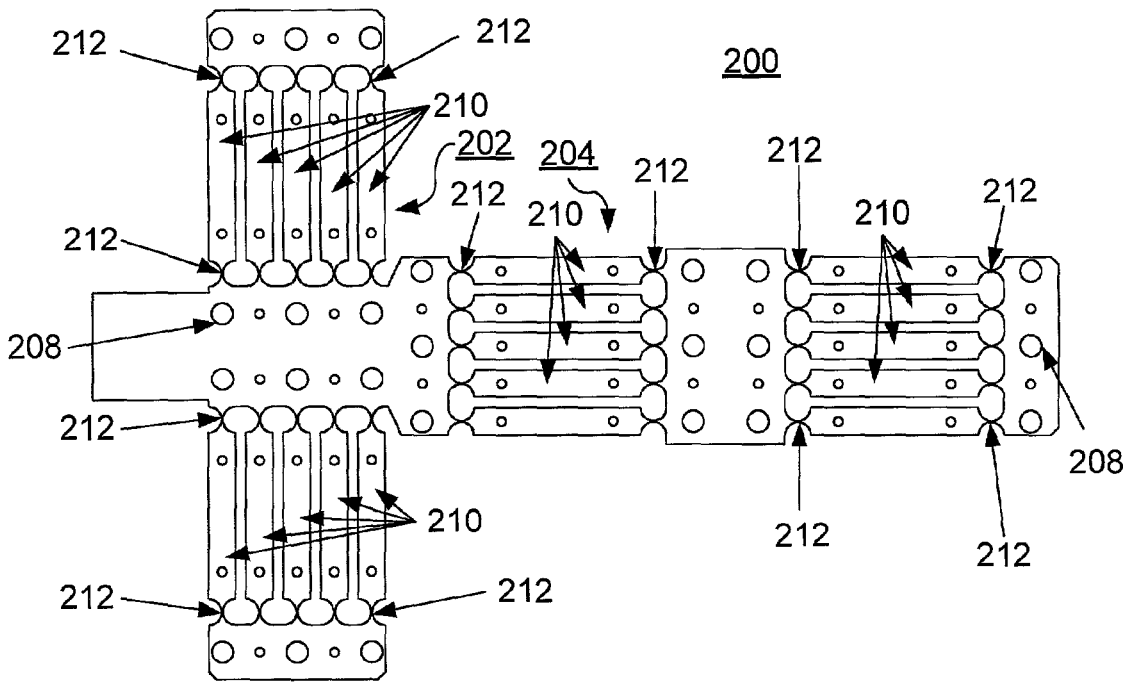

FIG.2

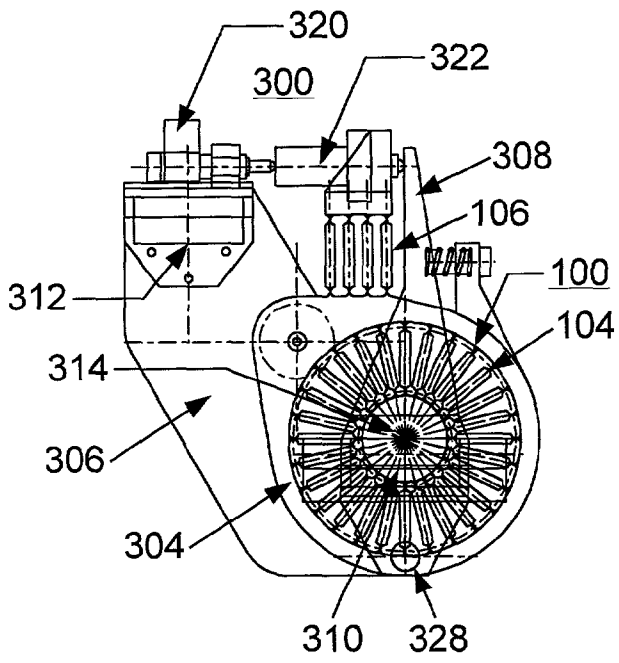

FIG. 3

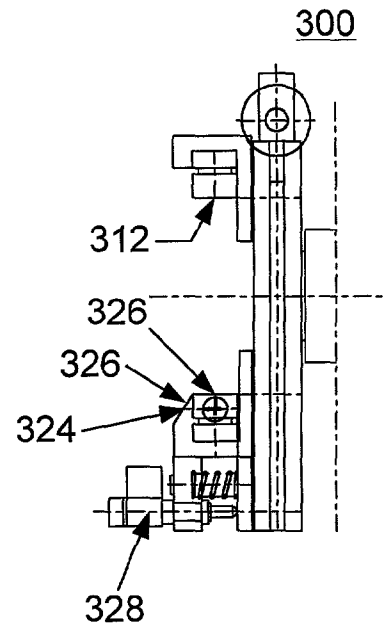

FIG. 4

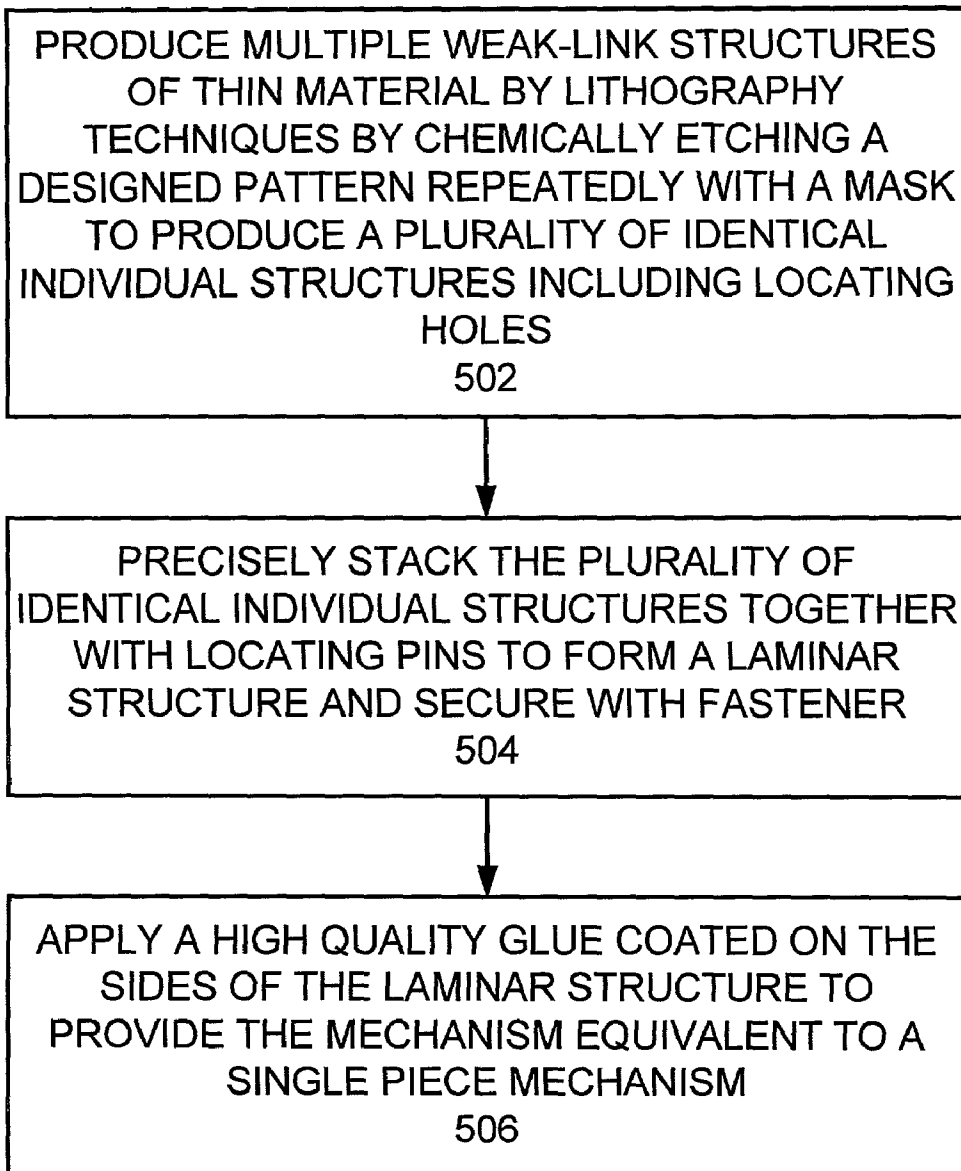

FIG.5

## REDUNDANTLY CONSTRAINED LAMINAR STRUCTURE AS WEAK-LINK MECHANISMS

[0001] This application claims the benefit of prior filed copending provisional application filed Oct. 11, 2000, by Deming Shu, Thomas S. Toellner, and Esen E. Alp, provisional application No. 60/239,599 and entitled REDUNDANTLY CONSTRAINED LAMINAR STRUCTURE AS WEAK-LINK MECHANISMS. The subject matter of the above-identified copending provisional application is incorporated herein by reference.

### CONTRACTUAL ORIGIN OF THE INVENTION

[0002] The United States Government has rights in this invention pursuant to Contract No. W-31-109-ENG-38 between the United States Government and Argonne National Laboratory.

### FIELD OF THE INVENTION

[0003] The present invention relates to a novel weak-link mechanism with redundant constrained structure, and more particularly, relates to redundantly constrained laminar structures as weak-link mechanisms and a novel method for manufacturing the redundantly constrained laminar structures as weak-link mechanisms.

### DESCRIPTION OF THE RELATED ART

[0004] Known weak-link mechanisms typically are single layer structures with usually only two connections. Fabrication techniques for the structures involve precision machining of individual blocks of metal or other material. This is expensive and difficult to achieve the desired precision. These single layer structures do not normally have the desired stiffness against flexing. In addition, the limitation of two connecting links is a factor in the instability of the structure during the small movements.

[0005] It is desirable to provide weak-link mechanisms that allow very small, controllable movements in certain directions while exhibiting a high level of stiffness to resist distortion in another direction. Unlike the traditional kinematics linear spring mechanisms, redundant constrained weak-link mechanisms should provide much higher structure stiffness and stability. A need exists for weak-link mechanisms in various instruments involving small, controllable movements to provide high sensitivity while maintaining stability in the positioning of a device or devices, such as optical devices or other devices.

[0006] A principal object of the present invention is to provide a novel weak-link mechanism with redundant constrained structure.

[0007] Another of the present invention is to provide redundantly constrained laminar structures as weak-link mechanisms.

[0008] Another of the present invention is to provide redundantly constrained laminar structures as weak-link mechanisms allowing very small, controllable movements in certain directions while exhibiting a high level of stiffness to resist distortion in another direction.

[0009] Another of the present invention is to provide a novel method for manufacturing the redundantly constrained laminar structures as weak-link mechanisms.

[0010] Another of the present invention is to provide a novel method for manufacturing the redundantly constrained laminar structures as weak-link mechanisms by a relatively inexpensive and precise technique of producing multiple, substantially identical, thin layers of a design with the controllable movement being in the plane of the layer and stacking the substantially identical, thin layers to form a structure having the desired stiffness and stability.

[0011] Other important objects of the present invention are to provide such manufacturing method and redundantly constrained laminar structures as weak-link mechanisms substantially without negative effect and that overcome some disadvantages of prior art arrangements.

### SUMMARY OF THE INVENTION

[0012] In brief, redundantly constrained laminar structures as weak-link mechanisms and a novel method for manufacturing the redundantly constrained laminar structures as weak-link mechanisms are provided. The method for producing the redundantly constrained laminar structures as weak-link mechanisms is carried out by lithographic techniques. A designed pattern is repeatedly chemically etched with a mask to produce a plurality of individual substantially identical units. The units are stacked together to form the laminar structure and are secured together. A high quality adhesive can be applied to the sides of the laminar structure to provide the mechanism equivalent to a single piece mechanism.

[0013] The redundantly constrained laminar structures as weak-link mechanisms of the invention include a stack of a plurality of thin material structures. The stack of structures forming a laminar structure include multiple weak-link connections providing controllable movements in a plane of the layer and having a desired stiffness and stability.

[0014] In accordance with features of the invention, the plurality of thin material structures include predetermined locating-holes used with locating-pins to precisely stack the thin material structures together and are used with fasteners to secure the stack together.

### BRIEF DESCRIPTION OF THE DRAWINGS

[0015] The present invention together with the above and other objects and advantages may best be understood from the following detailed description of the preferred embodiments of the invention illustrated in the drawings, wherein:

[0016] **FIG. 1** illustrates an exemplary redundantly constrained weak-link structure in accordance with the preferred embodiment;

[0017] **FIG. 2** illustrates another exemplary redundantly constrained weak-link structure in accordance with the preferred embodiment;

[0018] **FIGS. 3 and 4** illustrate an exemplary miniature multi-axis driving structure with a high-stiffness weak-link structure in accordance with the preferred embodiment; and

[0019] **FIG. 5** is a flow chart illustrating exemplary steps for manufacturing the redundantly constrained laminar structures as weak-link mechanisms.

### DETAILED DESCRIPTION OF THE PREFERRED EMBODIMENTS

[0020] Having reference now to the drawings, in **FIG. 1** there is shown an exemplary redundantly constrained weak-

link structure in accordance with the preferred embodiment generally designated by the reference character **100**. **FIG. 1** shows the shape of the metal weak-link sheet **102**, which is produced by a photochemical machining process. Two motion structures **104**, **106** are designed on the same metal sheet **102**. A wheel-shaped weak-link group **104** acts as a planar rotary shaft, and a parallelogram-shaped weak-link group **106** acts as a linear slide. To optimize the system stiffness, over-constrained mechanisms were chosen in this design of weak-link structure **100**. The precision of the modern photochemical machining process using lithography techniques makes it possible to construct a strain-free, or strain-limited, over-constrained mechanism on the thin metal sheet **102**. By stacking these thin metal weak-link sheets **102** with align-pins, a solid complex weak-link structure is constructed for a reasonable cost. Weak-link sheet **102** includes predefined locating-holes, such as holes **108**, used with locating pins to precisely stack the thin structures together to form the laminar weak-link structure **100**. Fasteners, such as bolts, are received in predefined locating-holes **108** to secure the weak-link sheets **102** together. Each weak-link group **104**, **106** includes more than two connecting links **110**, each having at least one or a pair of weak-link connections **112**, and preferably at least four connecting links **110**. Often a larger number of connecting links **110** is required for the controlled movement with stability, for example, as shown in weak-link group **104**. The multiple weak-link connections **112** provide controllable movements in a plane of the stack and the laminar structure **100** has a set stiffness and stability.

[**0021**] In our first prototype, 250- $\mu\text{m}$ -thick stainless steel sheets **102** were used. Each group consists of twenty weak-link sheets **102**. A 0.6-degree adjustment range was reached, which agreed with the finite element analysis result.

[**0022**] A finite element simulation for the wheel-shaped weak-link displacement was provided under a 0.89-Nm torsion load. In this case, the maximum displacement on the weak-link is 94  $\mu\text{m}$ , which corresponds to a 0.25-degree angular motion on the planar shaft, and the maximum stress in the weak region is 175 MPa, which is 72% of the yield stress as defined by von Mises criteria.

[**0023**] In **FIG. 2**, there is shown another exemplary redundantly constrained weak-link structure in accordance with the preferred embodiment generally designated by the reference character **200**. Redundantly constrained weak-link structure **200** is a doubly redundant constrained parallelogram. Redundantly constrained weak-link structure **200** include a pair of perpendicularly arranged parallelogram-shaped weak-link groups **202** and **204**. Redundantly constrained weak-link structure **200** is formed of multiple, thin material structures stacked together to form the laminar redundantly constrained weak-link structure **200**. Predefined locating-holes in each of the multiple, thin material structures, such as holes **208**, are used with locating pins to precisely stack the thin structures together to form the laminar weak-link structure **200**. Parallelogram-shaped weak-link groups **202** and **204** include a plurality of connecting links **210**, each having at least one or a pair of weak-link connections **212**. As shown in **FIG. 2**, each weak-link group **204**, **206** includes more than four connecting links **210**. The multiple weak-link connections **212** provide controllable movements in a plane of the stack and the laminar structure **200** has a set stiffness and stability.

[**0024**] In accordance with features of the invention, a novel miniature multi-axis driving structure **300** is provided that allows positioning of two crystals with better than 50-nrad angular resolution and nanometer linear driving sensitivity. The precision and stability of this structure **300** allow the user to align or adjust an assembly of crystals to achieve the same performance as does a single channel-cut crystal, so we call it an artificial channel-cut crystal. With the availability of third-generation of hard x-ray synchrotron radiation sources, such as the Advanced Photon Source (APS) at Argonne National Laboratory (ANL), x-ray inelastic scattering and x-ray nuclear resonant scattering provide powerful ways for investigating the vibration dynamics of a variety of materials and condensed matter systems.

[**0025**] The APS SRI-CAT 3-ID beamline is dedicated to high-energy-resolution x-ray scattering studies in the energy range of 6-30 keV. A special 2.7-cm-period undulator, optimized for peak brilliance is installed. The beamline's basic components include filters, white-beam slits, integral shutters, and a Kohzu double-crystal monochromator with water-cooled diamond crystals as a pre-monochromator. The beamline special components, such as custom-built high-resolution monochromators and a dual-function (collimating or focusing) x-ray mirror system, provide high flexibility for the optical system, so that users can optimize the beamline configuration for various applications. In particular, a 4-bounce high-resolution monochromator using a nested channel-cut crystal approach is used to deliver an x-ray beam with meV bandpass for x-ray inelastic scattering experiments.

[**0026**] There are design restrictions to the nested channel-cut geometry. Because these two channel-cut crystals are nested within each other, the size of the channel-cut crystals becomes an important design factor. The lack of availability of large crystals with good long-range crystallinity restricts the size of the outer channel-cut crystal. On the other hand, the input beam power absorbed by the first optical surface on the outer channel-cut crystal can reach a fraction of a Joule and can cause crystal local temperature and strain variations. In certain high-energy-resolution applications, these effects become major restrictions to the optical design. To overcome these obstacles, we have developed a novel miniature multi-axis driving structure **300** of **FIGS. 3 and 4**. The precision and stability of this structure **300** allow us to align or adjust an assembly of crystals to achieve the same performance as does a single channel-cut crystal, called an artificial channel-cut crystal. Using this structure **300**, we can make an outer channel-cut crystal large enough to optimize the nested monochromator's performance and compensate the crystal local temperature and strain variations.

[**0027**] The artificial channel-cut crystal was designed for a novel nested high-energy-resolution monochromator, which is optimized for an  $^{153}\text{Eu}$  nuclear resonance experiment at the energy of 21.542 keV. The high-energy-resolution monochromator uses a symmetric silicon (15 11 3) channel-cut crystal nested within an asymmetrically cut silicon (4 4 0) artificial channel-cut crystal. This optical design can produce a 1-meV resolution beam with a high throughput. However, if we use a natural channel-cut crystal to make the outer channel-cut crystal, the diffraction faces

can be separated by 200 mm, which makes it difficult to avoid problems associated with strain and temperature variations.

[0028] We use two asymmetrically cut silicon (4 4 0) crystals, which are each sized 25 mm×25 mm×60 mm, to act as an artificial outer channel-cut crystal. The major specification for the artificial channel-cut crystal structure is the angular alignment capability between the two crystals. Due to the 300-nrad Darwin width of the silicon (4 4 0) in this asymmetrically cut geometry, a 50-nrad pitch alignment resolution is needed. Long-term positioning stability is also very important to the artificial channel-cut crystal.

[0029] In a temperature-controlled environment ( $\pm 0.2^\circ$  C.), an angular drift rate less than 25-nrad per hour is required. Table 1 lists the design specifications for this (4 4 0) artificial channel-cut crystal.

TABLE 1

Design specifications for a (4 4 0) artificial channel-cut crystal	
Maximum Overall Dimension	216 mm ×
	212 mm ×
	92 mm
Main Shaft Diameter	10 mm
Maximum Thickness in Nested Area	30 mm
Single Crystal Size	25 mm ×
	25 mm ×
	60 mm
Number of Angular Alignment Axes	2
Angular Alignment Resolution (Pitch)	50 nrad
Angular Alignment Resolution (Roll)	600 nrad
Angular Alignment Stability (Pitch)	Drift less than
	25 nrad per hour
	100 nrad per hour
Angular Alignment Stability (Roll)	Drift less than
	2 degree
Angular Alignment Range (Pitch)	0.6 degree
Angular Alignment Range (Roll)	2 degree

[0030] FIGS. 3 and 4 illustrate an exemplary miniature multi-axis driving structure with a high-stiffness weak-link structure in accordance with the preferred embodiment generally designated by the reference character 300. Designing such a miniature multi-axis driving structure 300 with high stiffness and nanometer sensitivity is achieved in accordance with the preferred embodiment. Novelty of this new structure includes combining a closed-loop controlled piezoelectric transducer (PZT) technology with a novel high-stiffness weak-link structure generally designated by the reference character 304. High-stiffness weak-link structure 304 is substantially identical to the high-stiffness weak-link structure 100 illustrated and described with respect to FIG. 1.

[0031] Using stacked thin metal sheets configured and manufactured by chemical etching and lithography techniques, we were able to design a planar-shaped, high-stiffness, high-stability weak-link structure 304 for artificial channel-cut crystal use. To optimize the system stiffness, we have chosen over-constrained mechanisms in this design. The precision of modern photochemical machining processes using lithography techniques makes it possible to construct a strain-free, or strain-limited, over-constrained mechanism on thin metal sheets 102. By stacking these thin-metal weak-link sheets with alignment-pins, we can construct a solid complex weak-link structure for a reasonable cost. The test result shows that this novel weak-link

mechanism demonstrates a smooth 1:15 motion reduction ratio with high stiffness and stability. Driven by a closed-loop-controlled piezoelectric transducer with 1-nm positioning resolution, this mechanism 304 is capable of providing motion adjustments at the angstrom level.

[0032] FIGS. 3 and 4 illustrate an exemplary design of the miniature multi-axis driving structure 300 for an artificial channel-cut crystal. The structure 300 consists of three sub-assemblies: one base structure 306 and two crystal holders. The base structure 306 includes a compact sine-bar driving mechanism 308 for the crystal pitch alignment, which is a key component of the whole structure. There are two groups 104, 106 of stacked thin metal weak-link structures 304 mounted on each side of a base plate 306. A sine-bar 308 is installed on the center of a planar rotary shaft 310 for the pitch alignment between the two silicon (4 4 0) single crystals 312, 314. Two linear drivers 316, 318 are mounted on the base plate serially to drive the sine-bar 308. The rough adjustment is performed by a motorized micro-actuator for pitch adjustment 320, such as a Picomotor™, with a 20-nm to 30-nm step size. A closed-loop controlled piezoelectric transducer (PZT) 322, such as a Queensgate™ closed-loop controlled PZT 322 with capacitance sensor provides 1-nm resolution for the pitch fine alignment. A pair of commercial flexure bearings or springs 324 is mounted on one of the crystal holders 324, and a Picomotor driven structure 328 provides the roll alignment for the crystal 314.

[0033] We have tested the sensitivity of the weak-link sine-bar structure with a laser Doppler angular encoder. A 200-mm-long aluminum arm is mounted on the center of the planar rotary shaft, perpendicular to the sine-bar 308. A set of prisms is mounted at the end of the arm as a multi-reflection displacement sensor. During this test, a series of 5-nm incremental steps is applied to the sine-bar by the Queensgate PZT 322. A series of angular steps was recorded from the laser encoder. The average step size is 33 nrad with a 7 nrad RMS deviation.

[0034] We have tested the first prototype artificial channel-cut crystal as an outer crystal for a 4-bounce high-resolution monochromator with nested configuration at the Advanced Photon Source APS 3-ID-B experiment station at Argonne National Laboratory. As a typical case, a two-hour stability result with a 1-meV bandwidth monochromatic beam shows the change in transmitted intensity reflects the change in beam position, thermal changes, and crystal angle variations combined. At this point we have not isolated the contribution of the artificial channel-cut crystal assembly alone. However, we infer that, the contribution of the angular drift of two crystals attached to each other with the mechanism described here is very much less than 25 nrad per hour.

[0035] In brief summary, the solution provided here to bring two separate single crystals into a stable alignment at the level of interatomic distances enables new types of x-ray optics design that goes beyond the particular application mentioned earlier. Our motivation to solve a practical problem with respect to construction of a tunable high resolution monochromator with an energy bandpass of 1 meV above 20 keV has led to the high stiffness weak link mechanism design which is equally applicable to x-ray interferometers, and x-ray wave guides. Therefore, the immediate successful application to an artificial channel cut crystal assembly for inelastic x-ray scattering studies may be followed by other innovative applications.

[0036] With the availability of third-generation hard x-ray synchrotron radiation sources, such as the Advanced Photon Source (APS) at Argonne National Laboratory, x-ray inelastic scattering and x-ray nuclear resonant scattering provide powerful means for investigating the vibrational dynamics of a variety of materials and condensed matter systems. Novel high-resolution hard x-ray optics with meV energy resolution requires a compact positioning mechanism with 20-50-nrad angular resolution and stability. Multiple innovative applications exist for the redundantly constrained weak-link structure of the preferred embodiment, such as the redundantly constrained weak-link structure **100** of **FIG. 1**.

[0037] Referring now to **FIG. 5**, there are shown exemplary steps for manufacturing the redundantly constrained laminar structures as weak-link mechanisms. The method for producing the redundantly constrained laminar structures as weak-link mechanisms is carried out by lithographic techniques. A designed pattern is repeatedly chemically etched with a mask to produce a plurality of individual identical units formed of thin material and including locating holes as indicated in a block **502**. The units are stacked together precisely with locating-pins to form the laminar structure and are secured together with fasteners, such as bolts, as indicated in a block **504**. A high quality adhesive or glue can be applied to the sides of the laminar structure to provide the mechanism equivalent to a single piece mechanism as indicated in a block **506**.

[0038] While the present invention has been described with reference to the details of the embodiments of the invention shown in the drawing, these details are not intended to limit the scope of the invention as claimed in the appended claims.

What is claimed is:

1. A weak-link mechanism comprising:
  - a stack of a plurality of thin material structures;
  - said stack of structures forming a laminar structure; and
  - each of said stack of structures including multiple weak-link connections providing controllable movements in a plane of the stack and said laminar structure having a set stiffness and stability.
2. A weak-link mechanism as recited in claim 1 wherein each of said plurality of thin material structures include predetermined locating-holes, said locating-holes used with locating-pins to precisely stack said plurality of thin material structures.
3. A weak-link mechanism as recited in claim 2 wherein said stack of a plurality of thin material structures are secured together with fasteners received in predefined locating-holes and includes an adhesive coated to sides of said stack, whereby said laminar structure being substantially mechanically equivalent to a single piece mechanism.
4. A weak-link mechanism as recited in claim 1 wherein each of said plurality of thin material structures is formed of a metal.

5. A weak-link mechanism as recited in claim 1 wherein each of said plurality of thin material structures is formed of a thin stainless steel sheet.

6. A weak-link mechanism as recited in claim 1 wherein said multiple weak-link connections include a plurality of connecting links.

7. A weak-link mechanism as recited in claim 1 wherein said multiple weak-link connections include at least four connecting links.

8. A method for producing the redundantly constrained laminar structures as weak-link mechanisms by lithographic techniques comprising the steps of:

repeatedly chemically etching a designed pattern with a mask to produce a plurality of individual substantially identical units; and

stacking the units together to form the laminar structure.

9. A method for producing the redundantly constrained laminar structures as weak-link mechanisms as recited in claim 8 further includes the steps of securing the stacked units together with fasteners received in predefined locating-holes in said units; and applying an adhesive to the sides of the laminar structure to provide the mechanism substantially equivalent to a single piece mechanism.

10. A method for producing the redundantly constrained laminar structures as weak-link mechanisms as recited in claim 8 wherein each of said plurality of individual substantially identical units is formed of a thin material.

11. A method for producing the redundantly constrained laminar structures as weak-link mechanisms as recited in claim 8 wherein each of said plurality of individual substantially identical units is formed of a thin metal material.

12. A method for producing the redundantly constrained laminar structures as weak-link mechanisms as recited in claim 8 wherein the step of repeatedly chemically etching a designed pattern with a mask to produce a plurality of individual substantially identical units includes the step of repeatedly chemically etching a designed pattern having multiple weak-link connections with a mask to produce a plurality of individual substantially identical units.

13. A method for producing the redundantly constrained laminar structures as weak-link mechanisms as recited in claim 8 wherein the step of repeatedly chemically etching a designed pattern with a mask to produce a plurality of individual substantially identical units includes the step of repeatedly chemically etching a designed pattern with a mask to produce a set number of individual substantially identical units.

14. A method for producing the redundantly constrained laminar structures as weak-link mechanisms as recited in claim 13 wherein said set number of individual substantially identical units is selected for providing a predefined stiffness for the laminar structure.

\* \* \* \* \*