



US 20060022598A1

(19) **United States**

(12) **Patent Application Publication**
Lewellen et al.

(10) **Pub. No.: US 2006/0022598 A1**

(43) **Pub. Date: Feb. 2, 2006**

(54) **FIELD EMISSION CATHODE GATING FOR
RF ELECTRON GUNS AND PLANAR
FOCUSING CATHODES**

Publication Classification

(51) **Int. Cl.**
H01J 25/50 (2006.01)

(52) **U.S. Cl.** 315/39.57

(75) Inventors: **John W. Lewellen**, Plainfield, IL (US);
John Noonan, Naperville, IL (US)

(57) **ABSTRACT**

Correspondence Address:
Joan Pennington
535 North Michigan Avenue
Unit 1804
Chicago, IL 60611 (US)

A novel method of gating electron emission from field-emitter cathodes for radio frequency (RF) electrode guns and a novel cathode that provides a focused electron beam without the need for magnetic fields or a curved cathode surface are provided. The phase and strength of a predefined harmonic field, such as the 3rd harmonic field, are adjusted relative to a fundamental field to cause a field emission cathode to emit electrons at predefined times for the generation of high-brightness electron beams. The emission time is gated responsive to the combined harmonic and fundamental fields and the response of the FE cathode to the combined fields. A planar focusing cathode includes a selected dielectric material, such as a ceramic material, to provide an electron beam emission surface. Metal surfaces are provided both radially around and behind the dielectric material to shape the electric fields that accelerate and guide the beam from the cathode surface.

(73) Assignee: **THE UNIVERSITY OF CHICAGO**

(21) Appl. No.: **11/248,661**

(22) Filed: **Oct. 11, 2005**

Related U.S. Application Data

(62) Division of application No. 10/887,142, filed on Jul. 8, 2004.

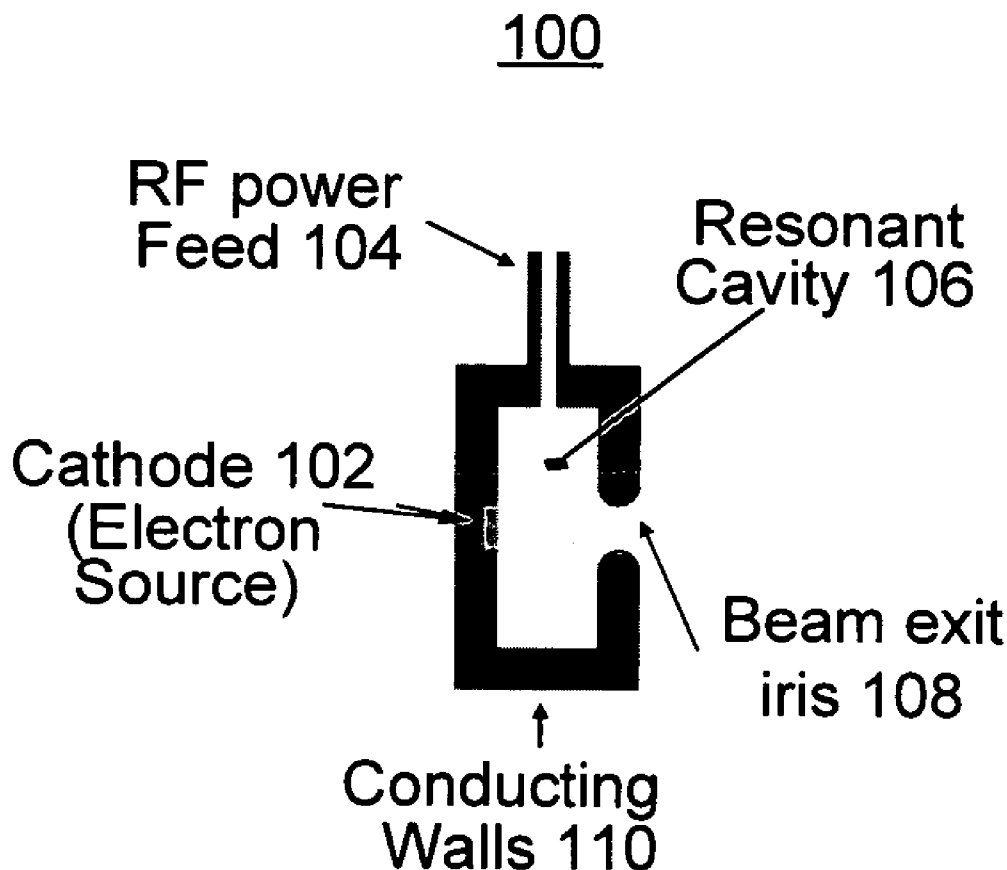

FIG. 1

100

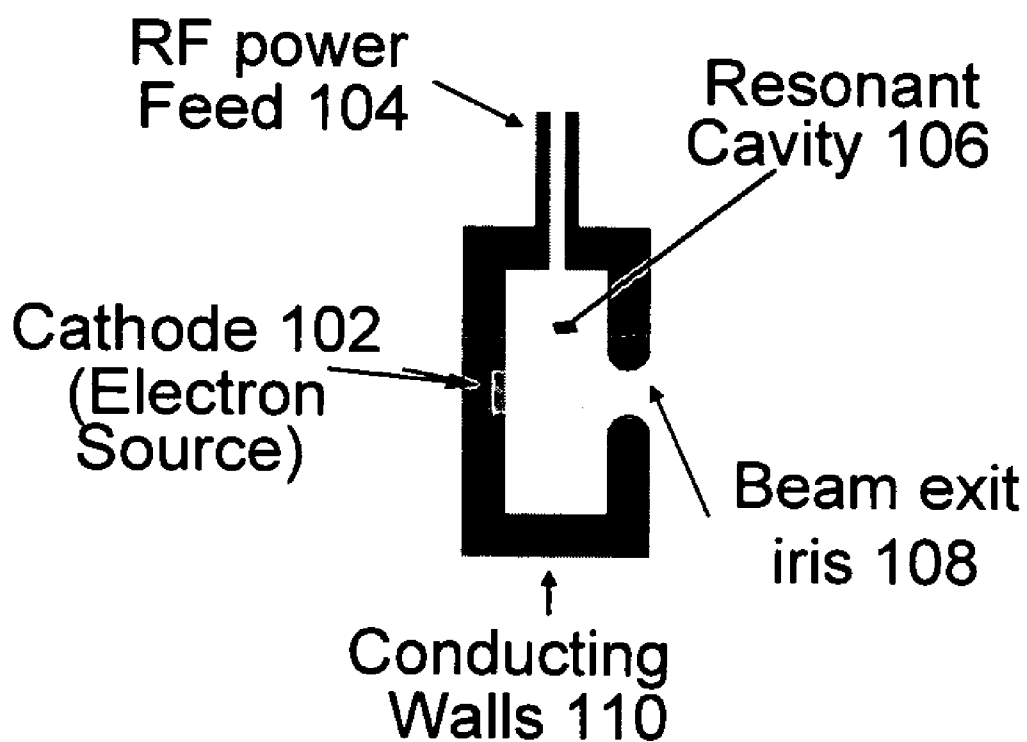

FIG. 2

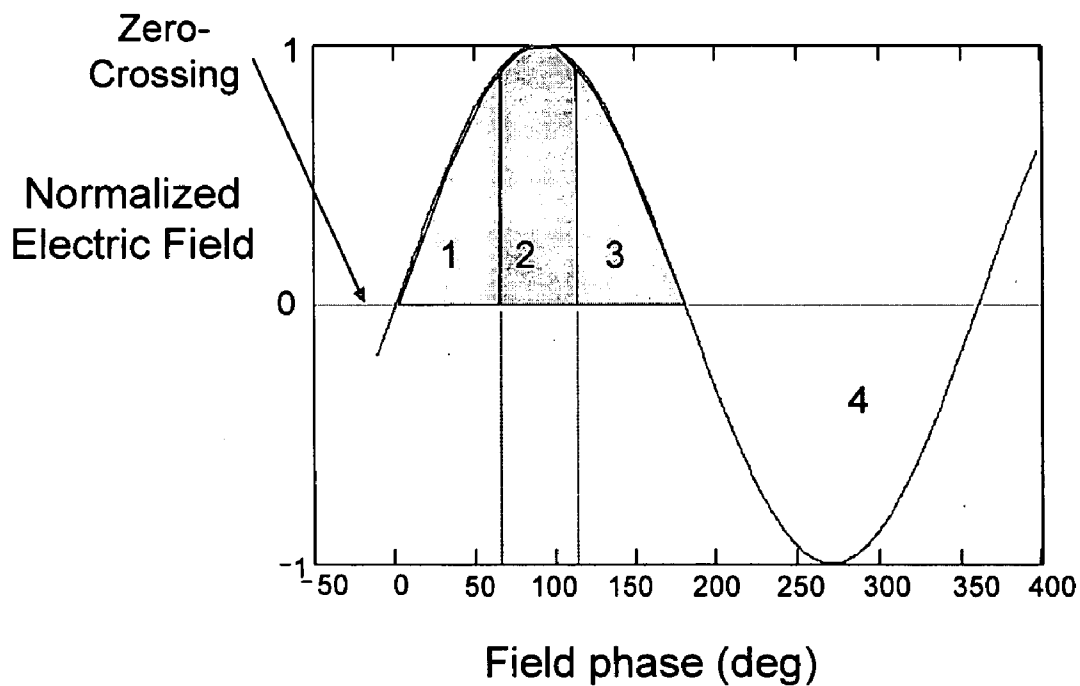

FIG. 3

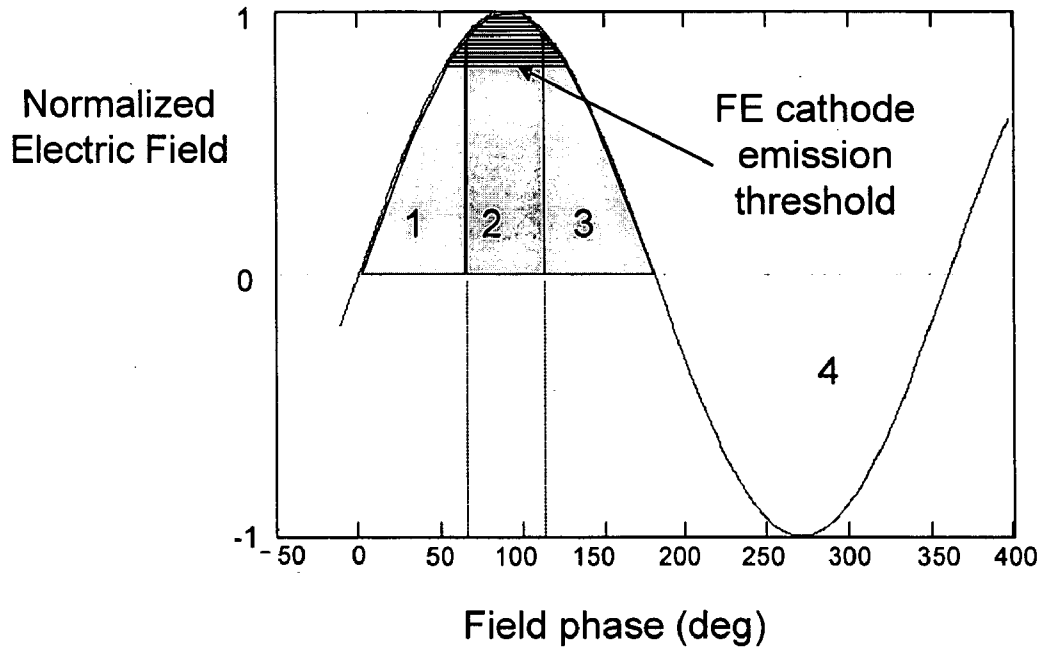

FIG. 4A

F = 1300 MHz

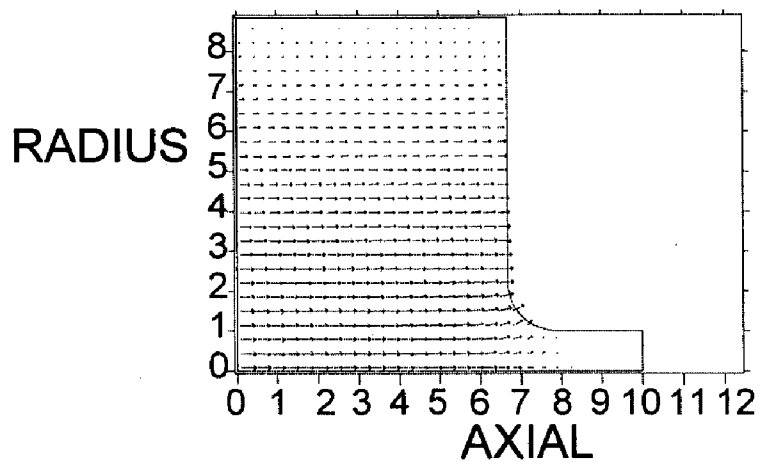

FIG. 4B

F = 2700 MHz

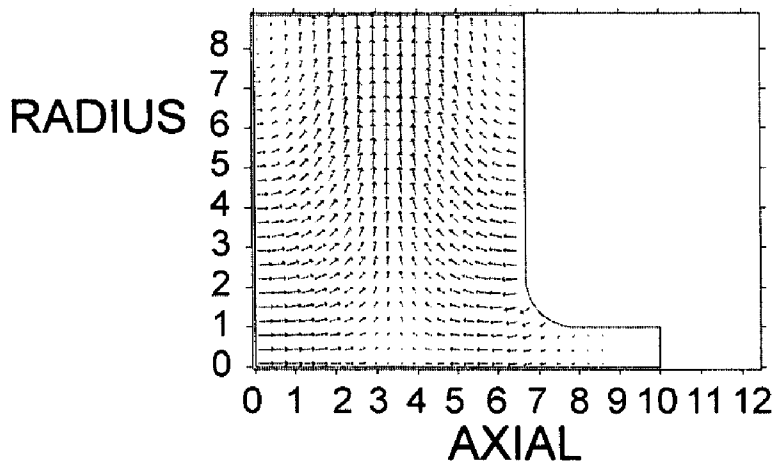

FIG. 5A

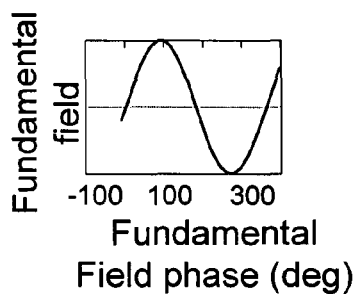

FIG. 5B

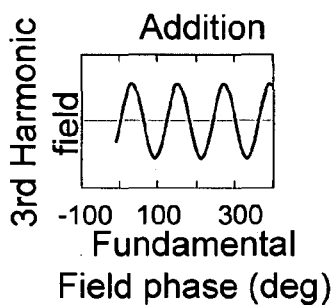

FIG. 5C

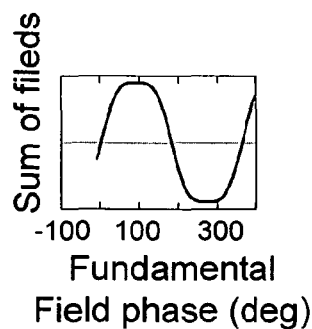

FIG. 5D

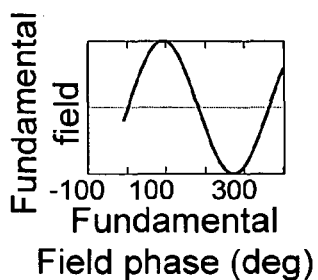

FIG. 5E

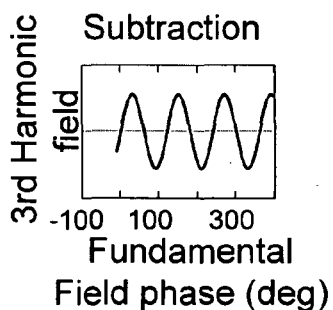

FIG. 5F

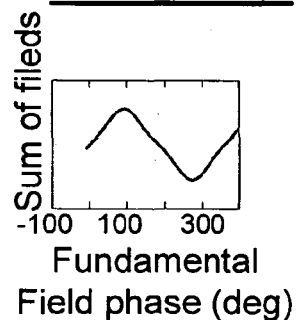

FIG. 6A

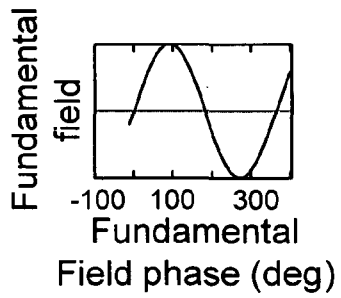

FIG. 6B

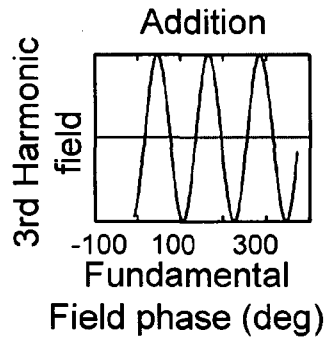

FIG. 6C

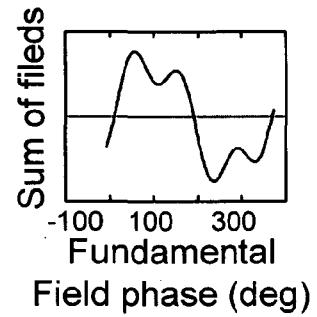

FIG. 7

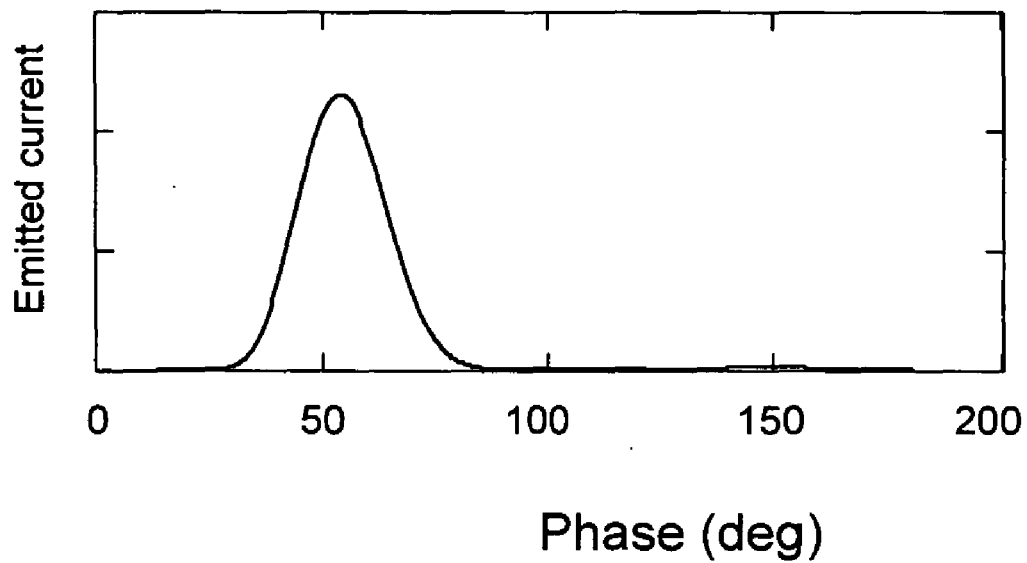

FIG. 8

FUNDAMENTAL CAVITY FIELD FOR EXEMPLARY TEST GEOMETRY

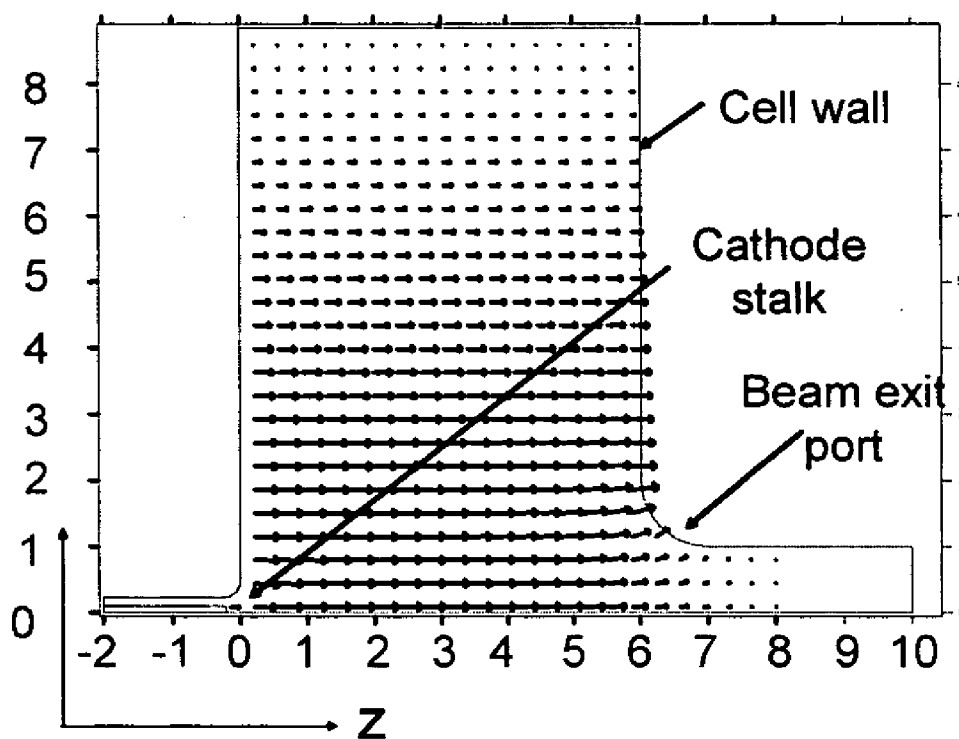

FIG. 9

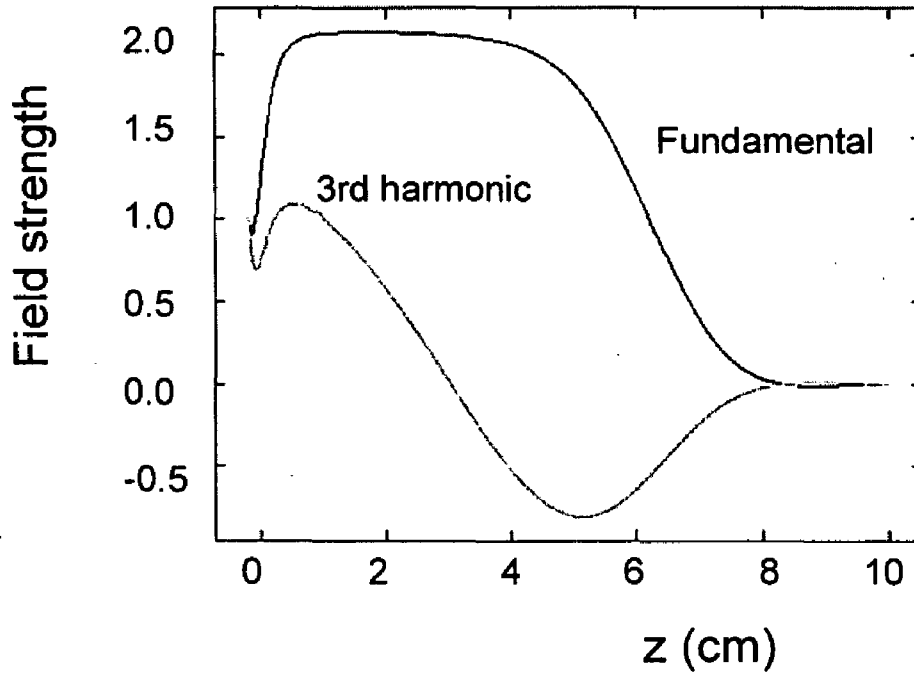

FIG. 10

1000

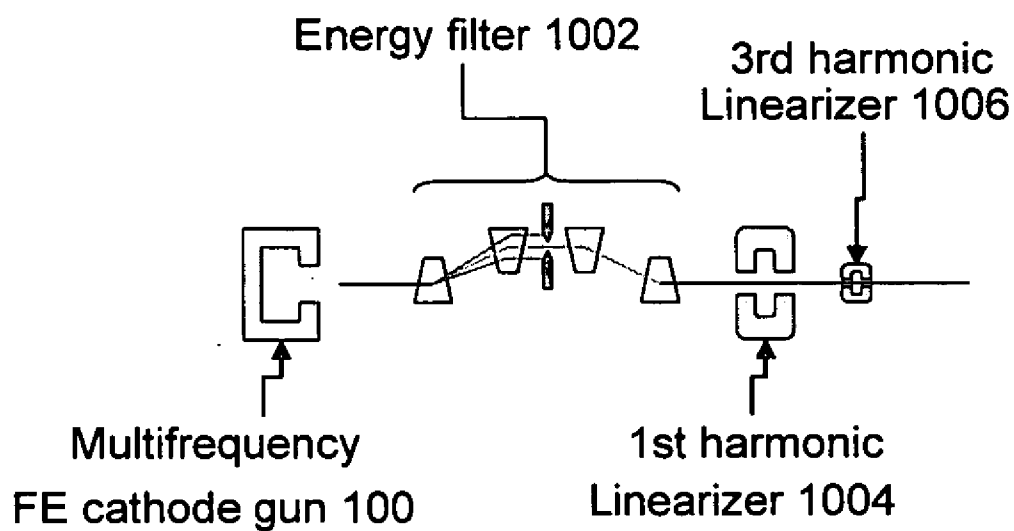

FIG. 11

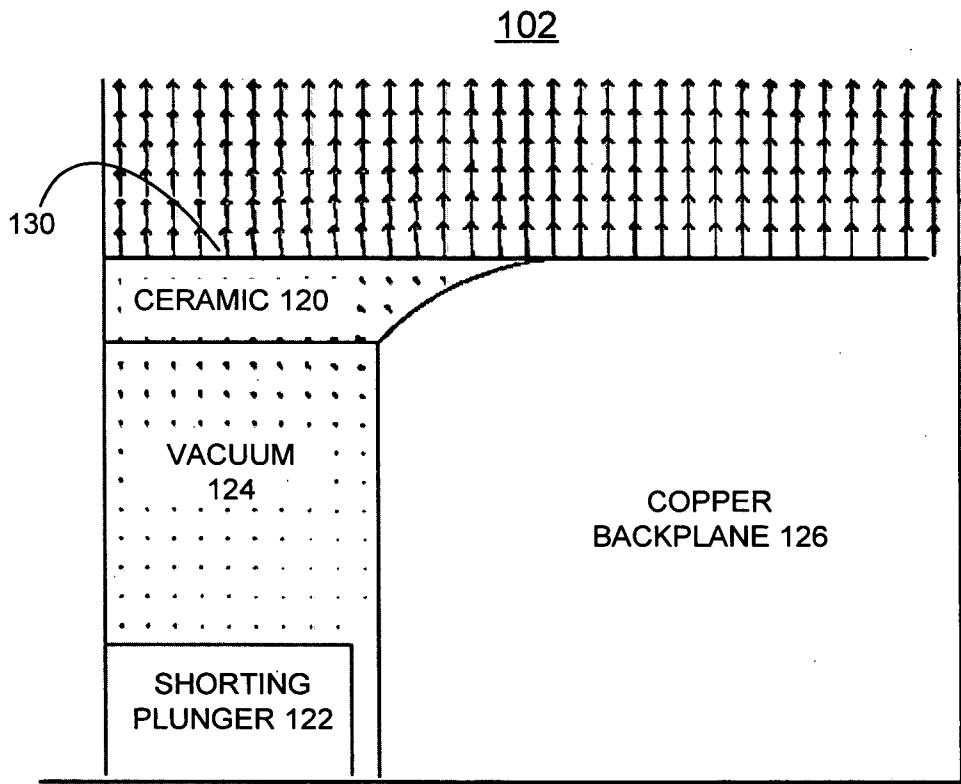

FIG. 12

OVERVIEW OF
PLANAR FOCUSING CATHODE
IN RF CAVITY

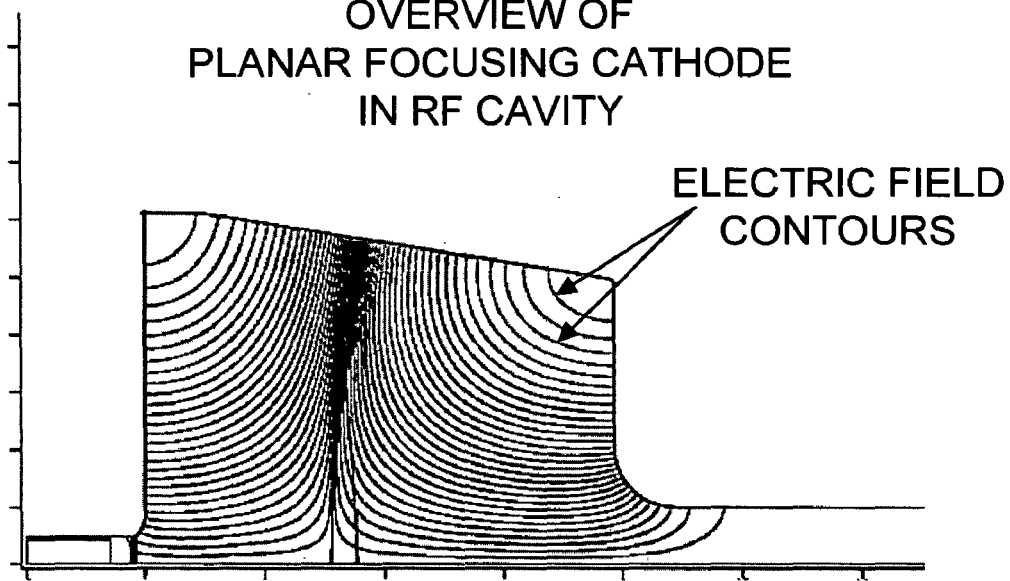
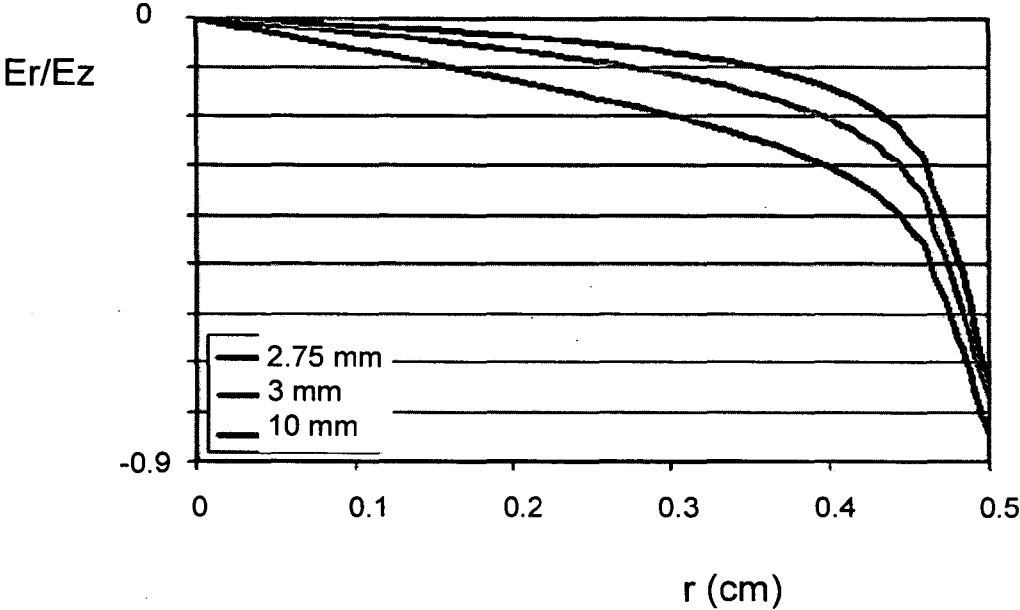

FIG. 13

NORMALIZED FOCUSING FIELD
AT CATHODE SURFACE



FIELD EMISSION CATHODE GATING FOR RF ELECTRON GUNS AND PLANAR FOCUSING CATHODES

CONTRACTUAL ORIGIN OF THE INVENTION

[0001] The United States Government has rights in this invention pursuant to Contract No. W-31-109-ENG-38 between the United States Government and Argonne National Laboratory.

FIELD OF THE INVENTION

[0002] The present invention relates to a novel method of gating electron emission from field-emitter cathodes for radio frequency (RF) electrode guns and planar focusing cathodes that are arranged for focusing an electron beam emitted from the cathode eliminating the need for either magnetic fields or a curved cathode surface.

DESCRIPTION OF THE RELATED ART

[0003] Most radio frequency (RF) electron guns constructed to date use either thermionic cathodes or photocathodes as their electron sources. Thermionic cathodes, which use high temperatures to induce electron emission from the cathode material, constantly emit electrons whenever the electric field in the gun is in the correct phase to accelerate electrons away from the cathode. Photocathodes use a light source, typically a high-power laser, to extract electrons from the photocathode surface.

[0004] Thermionic-cathode RF electron guns can typically produce very high average power electron beams, because of the continuous nature of the electron emission from the cathode, but can suffer from degraded beam quality because the electron emission cannot be gated to a particular fraction of an RF period. In addition, due to the requirements for high temperatures (ca 1300 C), thermionic cathodes are generally unsuited for use in superconducting RF electron guns (which generally require operating temperatures around four degrees above absolute zero).

[0005] Photocathode RF electron guns can produce very high-quality (bright) electron beams, because the use of a laser allows electron emission to be gated to a specific portion of the RF period, but most drive lasers cannot produce a laser pulse at every RF period. Therefore, the average beam power is typically lower than for a comparable thermionic-cathode RF electron gun. Photocathodes in common use typically offer a choice between either long lifetime and poor efficiency thus requiring a far larger drive laser, or poor lifetime and high efficiency requiring the use of a large cathode fabrication and processing system adjacent to the electron gun.

[0006] Field emission cathodes have generally not found widespread use in RF electron guns because they will, all other things being equal, emit the most charge when the applied electric field is highest. This is generally not the most desirable time for electron emission, and would result in a very poor-quality beam.

[0007] A concave cathode surface can be used for focusing an electron beam for RF electrode guns. This approach, however, has two primary disadvantages. First, the focusing thus provided is fixed; for any reasonable cathode design, altering the radius of curvature in situ while maintaining the

surface quality required to support high RF field strengths does not appear to be practical. Second, because the cathode is curved, unless a specially prepared drive laser is used, electron emission will start at the edges of the cathode before the center, and will likewise end at the edges of the cathode before ending at the center. These two effects are the primary reason such techniques are not more widely used in existing electron gun designs. In particular, the inability to alter the radius of curvature of the cathode, in effect the focusing force, has been seen as a strong disadvantage.

[0008] A principal object of the present invention is to provide a novel method of gating electron emission from field-emitter cathodes for radio frequency (RF) electrode guns.

[0009] Another principal object of the present invention is to provide a novel cathode that provides a focused electron beam without the need for magnetic fields or a curved cathode surface.

[0010] Other important objects of the present invention are to provide such method and cathode substantially without negative effect and that overcome some disadvantages of prior art arrangements.

SUMMARY OF THE INVENTION

[0011] In brief, a novel method of gating electron emission from field-emitter cathodes for radio frequency (RF) electrode guns and a novel cathode that provides a focused electron beam without the need for magnetic fields or a curved cathode surface are provided.

[0012] The method of gating electron emission from field-emitter cathodes for radio frequency (RF) electrode guns of the invention alters the emission time of a field-emitter (FE) cathode with respect to the RF period in the gun. The phase and strength of a predefined harmonic field, such as the 3rd harmonic field, are adjusted relative to a fundamental field to cause a field emission cathode to emit electrons at predefined times for the generation of high-brightness electron beams. The emission time is gated responsive to the combined harmonic and fundamental fields and the response of the FE cathode to the combined fields.

[0013] In accordance with features of the invention, this method provides advantages that a beam is produced every RF period while eliminating the need for a laser and the gated emission is produced at a most desirable time enabling high brightness electron beam production. Since the method does not rely on high temperatures to induce electron emission, it is compatible with superconducting RF electron guns as well as normal-conducting RF electron guns.

[0014] The novel cathode of the invention is a planar focusing cathode. The planar focusing cathode includes a selected dielectric material, such as a ceramic material, to provide an electron beam emission surface. Metal surfaces are provided both radially around and behind the dielectric material to shape the electric fields that accelerate and guide the beam from the cathode surface. The dielectric material can be penetrated by electric fields, allowing the planar focusing cathode to provide focusing for the electron beam starting at a substantially flat surface of the cathode dielectric material.

[0015] In accordance with features of the invention, the planar focusing cathode eliminates the use of magnetic

lenses, such as solenoids, between the electron gun and a following accelerator section.

BRIEF DESCRIPTION OF THE DRAWINGS

[0016] The present invention together with the above and other objects and advantages may best be understood from the following detailed description of the preferred embodiments of the invention illustrated in the drawings, wherein:

[0017] **FIG. 1** is a schematic diagram illustrating an exemplary 1-cell RF electron gun for implementing methods in accordance with the present invention;

[0018] **FIG. 2** is a chart illustrating beam emission timing for the RF electron gun of **FIG. 1**;

[0019] **FIG. 3** illustrates the FE cathode emission times during the RF period of **FIG. 2** for implementing methods in accordance with the present invention;

[0020] **FIGS. 4A and 4B** illustrate the two lowest modes or field patterns for the single-cell RF electron gun of **FIG. 1** in accordance with the present invention;

[0021] **FIGS. 5A, 5B, and 5C** illustrate the effect of adding a third-harmonic component to the fundamental, at a particular point in the RF cavity, as a function of the phase of the fundamental field in accordance with the present invention;

[0022] **FIGS. 5D, 5E, and 5F** illustrate the effect of subtracting a third-harmonic component to the fundamental, at a particular point in the RF cavity, as a function of the phase of the fundamental field in accordance with the present invention;

[0023] **FIGS. 6A, 6B, and 6C** illustrate the effect of adding a third-harmonic component to the fundamental, at a particular point in the RF cavity, as a function of the phase of the fundamental field for another selected proportionality constant and phase of the 3rd harmonic field in accordance with the present invention;

[0024] **FIG. 7** illustrates an exemplary FE cathode emission profile during the RF period of **FIGS. 6A, 6B, and 6C** for implementing methods in accordance with the present invention;

[0025] **FIG. 8** illustrates FE cathode gun cell test geometry used for simulations in accordance with the present invention;

[0026] **FIG. 9** illustrates the fundamental and 3rd harmonic fields strength plotted as distance along the axis of the gun of **FIGS. 1 and 8** in accordance with the present invention;

[0027] **FIG. 10** illustrates an exemplary application of the gun of **FIGS. 1 and 8** in accordance with the present invention;

[0028] **FIG. 11** is a detailed view of the RF electron gun of **FIG. 1** illustrating a novel planar focusing cathode that provides a focused electron beam in accordance with the present invention;

[0029] **FIG. 12** illustrates exemplary electric field contours of the planar focusing cathode of **FIG. 11** in accordance with the present invention; and

[0030] **FIG. 13** illustrates exemplary normalized radial electric field at the cathode surface of the planar focusing cathode of **FIG. 11** in accordance with the present invention.

DETAILED DESCRIPTION OF THE PREFERRED EMBODIMENTS

[0031] In accordance with features of the invention, a general method for altering the emission time of a field-emitter cathode with respect to the RF period in the gun. This approach combines the advantages of the thermionic-cathode RF electron gun (beam produced every RF period, no laser needed) with those of a photoinjector (gated emission at the most desirable time, high brightness, superconducting RF-compatible). The resulting design enables broad applicability across a number of fields.

[0032] In accordance with features of the invention, a planar focusing cathode, also referred to as a standoff cathode, provides a means of focusing an electron beam emitted from the cathode of a high-brightness RF electron gun, without requiring the use of either magnetic fields, or a curved cathode surface. The application is for high-brightness electron guns in devices such as linear colliders, free-electron lasers, and the like.

[0033] Having reference now to the drawings, in **FIG. 1** there is shown an exemplary RF electron gun generally designated by the reference character **100** that can be used for implementing methods in accordance with the present invention. The RF electron gun **100** is a single cell or 1-cell RF electron gun that is essentially a box in which an oscillating electromagnetic field is generated. The RF electron gun **100** includes a cathode **102** that provides an electron source. The RF electron gun **100** includes an RF power feed **104** that is used to establish an oscillating electromagnetic field inside a resonant cavity **106**. This field is used to accelerate electrons emitted from the cathode **102** out a beam exit iris **108** provided within conducting walls **110** defining the resonant cavity **106**.

[0034] In general, RF electron guns work by establishing an oscillating electromagnetic field inside a cavity, or series of cavities, such as resonant cavity **106** defined by conducting walls **110**. This field is used to accelerate electrons emitted from a cathode, down the bore of the gun, and out an exit port, such as from cathode **102** and out beam exit iris **108**. The phase of the RF field at which a given electron is emitted from the cathode **102** determines whether it can exit the cavity **106**, and, if so, at what energy. Electrons attempting to leave the cathode **102** too early in phase, before the so-called zero-crossing, cannot exit the cathode at all because the electric field in the cavity is the wrong sign. Electrons emitted too late in phase cannot exit the RF electron gun **100** before the electric field reverses sign; these electrons will be decelerated before they can exit the gun. This can cause the overall electron beam quality to suffer. Electrons emitted still later will have their direction of flight reversed, and will return to strike somewhere in the vicinity of the cathode. This phenomenon is called back-bombardment.

[0035] **FIG. 2** illustrates, for a single RF period, the fate of emitted electrons as a function of phase including a plurality of regions respectively labeled **1, 2, 3** and **4**. Although the exact dependence of electron beam quality and energy as a function of launch phase depends very strongly

on details of the gun design and construction, some general features can be identified. Electrons emitted during region 1, between 0 degrees and (approximately) 60 degrees, will exit the gun with reasonable beam quality and comparatively high electron beam energy. Electrons emitted during region 2 will exit the gun, but with greatly degraded beam quality and lower beam energy. Generally, there is a smooth transition between regions 2 and 3, from which electrons will be emitted from the cathode but which will not be able to exit the gun; many of these electrons, in fact, will reverse direction and strike the cathode. Finally, in region 4, electrons cannot be emitted from the cathode because the electric field on the cathode is the wrong sign. Other properties of the beam, such as divergence, will change smoothly with emission phase.

[0036] Having reference to FIG. 2, this provides a ready illustration of the relative advantages and disadvantages of photocathodes vs. thermionic cathodes. Thermionic cathodes emit electrons continuously, and so can generate very high average power electron beams; however, much of their emission occurs during regions 2 and 3. Electrons emitted during region 3 are by definition not relevant to the final electron beam quality, but they still take energy to accelerate. The entire beam consists of a mixture of electrons emitted during region 1 and region 2, resulting in a considerably lowered overall beam quality.

[0037] Photocathodes emit electrons only when struck with an appropriate pulse of light, as from a drive laser. Thus, it is possible to gate the electron emission to only a very narrow slice within region 1, yielding a very high-quality electron beam. The drive laser, however, adds considerable cost and complexity to the system, and cathode material limitations appear, at the present time, to prohibit both high-duty-cycle and highly robust operation.

[0038] Finally, field emission (FE) cathodes operate by using strong electric fields to pull electrons from the cathode material directly. Thus, unlike thermionic cathodes, they do not emit continuously. Unlike photocathodes, their triggering mechanism does not rely on an external event such as the arrival of a laser pulse. Rather, FE cathodes do not emit electrons below a threshold electric field. Above that threshold, which can be varied significantly depending on the cathode design, FE cathodes will begin to emit electrons, with the emission current increasing rapidly with increasing electric field.

[0039] At first glance, this behavior would seem to make FE cathodes a very appealing alternative to both thermionic and photocathodes. The difficulty, however, lies in that the FE cathode will emit the highest current when the electric field gradient is the strongest; the emission will be symmetric about the 90° point.

[0040] FIG. 3 illustrates the FE cathode emission times during the RF period of FIG. 2. It is apparent that the FE cathode will emit most of its beam current during region 2 of the RF period. The resulting beam will typically have a very large energy spread, and very poor transverse quality. Worse, some of the beam, emitted during region 3, may return to the cathode and damage it via the back-bombardment process. In general, the emission from the FE cathode will be too long in duration, and will occur at the wrong part of the RF period.

[0041] In fact, this description applies very well to the dark current observed during the operation of some high-

field RF photocathode guns, so named as it describes electrons emitted without the presence of a drive laser pulse. In these cases, imperfections on the photocathode surface act as FE cathodes. The resulting beams are typically low energy, with large energy spreads and exceedingly poor transverse beam quality.

[0042] Potential mechanisms for addressing some of these shortcomings, such as shortening the cell containing the cathode, do not provide sufficient improvement so as to make the FE cathode a viable choice for RF electron guns.

[0043] A given RF cavity is typically capable of supporting many different field patterns oscillating at many different frequencies. A specific pattern at a specific frequency is usually identified as a cavity mode.

[0044] FIGS. 4A and 4B illustrate the two lowest modes, or field patterns, for the same single-cell RF electron gun. Typically, RF electron guns are designed to operate using a single mode in the cavity. Typically, the RF electron gun is designed to use the lowest-frequency, or fundamental, mode. In this case, the two modes shown are the two lowest frequencies the cavity is capable of supporting. The higher frequency of FIG. 4B is not an exact harmonic or integer multiple of the lower frequency of FIG. 4A. Plot axes of FIGS. 4A and 4B are r (radius) vs. z (axial) coordinates. The arrows represent the direction and strength of the electric field in the cavity.

[0045] It is possible to tune a cavity such that at least some of the modes are harmonic. For instance, it is possible to tune the cavity such that the third cavity mode oscillates at exactly three times the frequency of the fundamental mode. The fields in the cavity will then beat in phase with each other. (Some work has been performed using such a field sum to generate what appears to be a flat cavity field. The thrust of the prior work, however, had been to generate approximately uniform fields in space rather than in time.)

[0046] FIGS. 5A, 5B, and 5C illustrate the effect of adding a third-harmonic component to the fundamental, at a particular point in the RF cavity, as a function of the phase of the fundamental field.

[0047] FIGS. 5D, 5E, and 5F illustrate the effect of subtracting a third-harmonic component to the fundamental, at a particular point in the RF cavity, as a function of the phase of the fundamental field.

[0048] At first glance, this does not appear to be particularly useful in that, although we can evidently control the duration of the peak field (expand into a flat-top as in FIG. 5C, or sharpen as in FIG. 5F), the peak field is still centered squarely in region 2.

[0049] The field addition can be represented as follows:

$$E_{\text{sum}}(t) = E_1 \sin(\omega_1 t + \phi_1) + E_3 \sin(3\omega_1 t + \phi_3) \quad (1)$$

where ω_1 represents the angular frequency of the fundamental field, E_1 , E_3 represents the respective amplitude of the fundamental field and the 3rd-harmonic field, ϕ_1 , ϕ_3 represents the respective phase of the fundamental field and the 3rd-harmonic field, and t is time. We can choose to set $\phi_1 = 0$, and we can also write $E_3 = \alpha E_1$ where α is simply a proportionality constant. In FIGS. 5A, 5B, and 5C, in effect, $\alpha = 1/9$, and $\phi_3 = 0^\circ$ for case of addition, and in FIGS. 5D, 5E, and 5F $\alpha = 1/9$, and $\phi_3 = 180^\circ$ for case of subtraction.

[0050] Referring now to FIGS. 6A, 6B, and 6C, α and ϕ_3 may be set to be whatever values desired. FIGS. 6A, 6B, and 6C illustrate the effect of adding a third-harmonic component to the fundamental, at a particular point in the RF cavity, as a function of the phase of the fundamental field for another selected proportionality constant set to $\alpha=0.4$ and phase of the 3rd harmonic field of $\phi_3=-40^\circ$.

[0051] Two features can be seen having reference to FIGS. 6A, 6B, and 6C. First, the width of the peak field has narrowed considerably, compared to the fundamental alone. Second, and most importantly, the peak of the field has shifted from 90° to approximately 50° . Therefore, with an appropriately chosen emission threshold, the FE cathode will emit electrons around the 50° point, within region 1.

[0052] FIG. 7 illustrates an example calculated emission profile for the fields shown in FIGS. 6A, 6B, and 6C.

[0053] In accordance with features of the invention, by adjusting the phase and strength of the 3rd harmonic field relative to the fundamental field, we cause a field emission cathode to emit electrons at times appropriate for the generation of high-brightness electron beams. The emission time is gated by the combined fields and the response of the FE cathode to the combined fields; much as a photocathode's emission is gated by its drive laser. Like a thermionic cathode, the FE cathode's emission is not determined by the presence or absence of a laser pulse; therefore, the cathode will produce beam at every RF period.

[0054] Therefore, this technique of the invention permits the combination of appropriately gated emission, for high-brightness beam production, with emission during every RF period, for high-average-power operation. This summation of fields in the cavity represents, in effect, the first two terms of a Fourier series describing an ideal driving field for a field-emission cathode gun. In principle, additional improvements to the field shape could be made, for example, generating a small flat-top distribution, by adding more fields at higher harmonics. In practice, this rapidly becomes less practical for two important reasons.

[0055] First, a reasonable method is required for coupling the harmonic power into the cavity, along with a suitable high-power microwave source. For the style of cavity, such as cavity 106 illustrated in FIG. 1, coupling power into the cavity via an on-axis coupler at the exit of the gun 100 can be provided together with using a cathode stalk or recess region as another input coupler. Adding another harmonic requires another coupling port, for example, machined to even higher precision due to the higher frequency, isolated from the first two harmonics. The same problems must be solved again for each successive harmonic added.

[0056] Second, the cavity 106 must be resonant at all harmonic frequencies in order to build up reasonable field strengths. For the lowest cavity mode or the fundamental mode, the cavity radius is the dominant factor in determining resonant frequency. For all other modes, both the cavity radius and the length are important in determining the resonant frequency. Therefore, to an extent, with two harmonics one can set the radius of the cavity to tune for the desired fundamental, and then adjust the length to tune in the 3rd harmonic. This solves the resonant frequency problem without resulting to highly speculative cavity designs.

[0057] It should be understood that while it may be possible in principle to add still higher harmonic fields to the

cavity, and while this may be of some benefit, the primary concept of gating the field-emission cathode to a useful beam launch time does not depend on doing so. Also by adding the 5th harmonic component, rather than the 3rd harmonic component, does not offer any obvious advantages in terms of beam quality, and results in more peaks in the field sum. The result is that emission is not as cleanly gated to the desired time; instead, emission can occur at multiple times during the fundamental RF period, leading to the risk of contaminating the desired beam.

[0058] There are additional considerations to be addressed in order to apply this technique of the invention to produce a viable electron beam source. In particular, in order to obtain the properly gated electron emission as noted above, the 3rd harmonic field has to be quite strong in comparison to the fundamental field. For good beam dynamics in the gun, however, the fundamental field must dominate as the beam moves from the cathode to the exit. The addition of a modest 3rd harmonic field can benefit beam transport, however, the required phase and amplitudes of the 3rd harmonic are shown with respect to FIGS. 5A, 5B, 5C, which is unsuitable for FE cathode gating.

[0059] A method is therefore required to obtain a strong 3rd harmonic field component at the cathode 102, while minimizing its effects elsewhere in the cavity 106. This is accomplished as follows. The gun cavity 106 contains a recess where the cathode would ordinarily be, for example, as illustrated in FIGS. 8 and 11. The FE cathode is placed on a stalk recessed slightly into this cavity. The 3rd harmonic field will penetrate into the recess more deeply than the fundamental field, due to its higher frequency and, therefore, shorter wavelength.

[0060] Thus, the 3rd harmonic field will be strong, relative to the fundamental field, at the cathode surface where it is required to properly gate the FE cathode emission. In the body of the gun, however, the fundamental will dominate, yielding dynamics similar to those of a conventional gun.

[0061] FIG. 8 illustrates FE cathode gun cell test geometry used for simulations.

[0062] FIG. 9 illustrates the fundamental and 3rd harmonic fields, plotted as distance along the axis of the gun.

[0063] Note that the fundamental field has twice the strength in the body of the cavity as it does at the tip of the cathode and that the 3rd harmonic field is twice as strong at the cathode tip as it is in the majority of the body of the cell. Therefore, for equal fields at the cathode tip, the 3rd harmonic is $\frac{1}{4}$ as strong in the body of the cell. With $\alpha=0.4$, then, the fundamental is a factor of 10 stronger in the body of the cathode cell. This meets our requirement that the fundamental field dominate the beam dynamics in the main body of the cell.

[0064] This is not an ideal process; in particular, the beam energy spread is higher than desired, and further manipulation advantageously is performed to make the beam more generally useful. However, this is true of both photocathode and thermionic-cathode electron guns. The significant advantage here is the ability of the FE cathode gun to produce a beam that can be so manipulated, potentially in a package which is superconducting, and thus makes extremely efficient use of the available RF power. These manipulations are fairly routine.

[0065] The examples of **FIGS. 8 and 9**, and the following sample calculations, are based on the choice of a 1.3 GHz fundamental RF frequency, with a corresponding 3rd harmonic at 3.9 GHz.

[0066] This particular choice of fundamental frequency was driven by three considerations. First, there are several commercial RF power sources available in the range needed for the e-microscope application as illustrated in **FIG. 10**. Second, L-band cavities are of a size that is a good compromise between machining tolerances, where lower frequencies are better, with compactness. Finally, the TESLA superconducting accelerator structures are designed to operate at L-band, so there is already a large and growing community knowledgeable about making superconducting cavities, and associated systems, in this frequency range. In brief, it should be understood that this particular choice of fundamental frequency simply is a convenient first choice.

[0067] It should be understood that the present invention is not limited to this selection of frequency. Considerations exist and arguments can be made for going to either lower or higher frequencies. It should be emphasized and understood that the FE cathode gating method of the present invention will, in general, operate independently of the choice for the fundamental frequency. This is the addition of harmonic fields with a defined relationship in phase; therefore, everything scales with the fundamental frequency. This includes, for instance, the bunch length, which with longer (shorter) frequency will become longer (shorter) in time, but which will have the same length when expressed in terms of degrees of RF phase. This has important implications for beam dynamics also, as it means that the basic performance should be maintainable across a broad range of frequency choices. The ability of the cavity to properly support and accelerate a given beam current does change somewhat with frequency, but in general is more limited by the available RF power than by the particular design of the cavity or choice of resonant frequency.

[0068] These calculations also do not incorporate some of the advanced cathode designs, such as, in particular a planar focusing cathode of the invention as illustrated and described with respect to **FIGS. 11, 12, and 13**. Such planar focusing cathodes are designed to help counter strong space-charge forces acting on the beam as it leaves the cathode. The sample applications below typically assume very low bunch charges; the modest average beam current comes from every bucket being filled (i.e. one bunch generated per RF period) and the high beam power from the combination of moderate current and high beam energy.

[0069] For higher-current applications, such as for a free-electron laser driver, it is anticipated that the planar focusing cathode of the invention advantageously can be combined with the FE cathode gating technique of the invention. It should be understood, however, that both the planar focusing cathode of the invention and the FE cathode gating technique of the invention represent different basic technologies and techniques and should be considered independently on their own merits.

[0070] **FIG. 10** illustrates an exemplary application of the gun of the invention, for example, as illustrated in **FIGS. 1 and 8** in accordance with the present invention. The initial goals for this design were based on the needs for electron microscopy. Thus, emphasis was placed on reducing the

beam emittance (i.e. improving transverse quality) and energy spread, while generating modest beam currents. For these simulations, the chosen bunch charge was 0.385 pC, or an average beam current of 0.5 mA if an electron bunch is produced every RF period. The electron charge distribution was generated initially according to the profile shown above, and later approximated by a Gaussian distribution.

[0071] In **FIG. 10** there is shown an exemplary simulated beamline layout generally designated by the reference character **1000** in accordance with the present invention. An energy filter **1002** introduces a correlation between the beam energy and position, allowing a narrow slice to be transmitted from the core of the beam. This results in both a reduced energy spread and an improved transverse quality, because the core of the beam generally is the portion where the transverse quality is highest. PARMELA was used to simulate the entire beamline. A Gaussian longitudinal distribution was used as a surrogate for the actual FE cathode emission profile, for ease of scaling to larger particle counts. The electron gun **100** coupled to the energy filter **1002** is a multifrequency FE cathode gun as described above. A cathode 0.1 mm in diameter was assumed, generating an initial beam current of 0.5 mA on average. The applied fields were as those above, with a peak field on the cathode of about 25 MV/m. The energy filter was set to transmit about 20% of the beam current, or 0.1 mA. Finally, a first-harmonic linearizer **1004** reduces the beam energy spread by 2 orders of magnitude and a third-harmonic linearizer **1006** reduced the beam energy spread by another order of magnitude.

[0072] At the end of this simulated beamline, the beam current is about 90 μ A. The average beam energy is 1.786 MV. The root mean square (RMS) fractional energy spread is $1.7 \cdot 10^{-5}$, or about 30 volts in absolute terms. The horizontal and vertical normalized emittances are $1.2 \cdot 10^{-3}$ and $1.0 \cdot 10^{-3}$ μ m, respectively. The difference arises because the energy filter **1002** bends the beam in the horizontal plane. This should be sufficient to generate a beam spot about 1 nm in radius, given good electron-beam optics. The total electron beam power is about 180 W. The beam power from the gun is closer to 900 W; the scrapers in the energy filter absorb the difference. Therefore, the power density on at the spot could in principle be approximately 51 GW per square mm. Further reducing the transmission of the filter will result in additional improvements to beam quality, at the expense of current.

[0073] It should be understood that the present invention is not limited to the illustrated application of **FIG. 10**. For example, if the energy filter **1002** is removed from the beamline, thereby passing all of the beam current, the first-harmonic linearizer **1004** and the third-harmonic linearizer **1006** can still be used to reduce the beam energy spread. In this case, the beam energy is around 1.4 MV and the final energy spread is $1.7 \cdot 10^{-4}$ rms (or about 300 volts). The beam energy is lower than above, and the energy spread is larger, because the energy filter **1002** is not removing the "wings" of the incoming electron beam. Thus, a different minima for the energy spread is found. The transverse quality is also worse, at about $4 \cdot 10^{-3}$ μ m. On the other hand, the entire beam current of 0.5 mA is transmitted, for a final beam power of about 700 W.

[0074] As a comparison, a typical electron beam welder might have a beam power of 15 kW, with a voltage of 60 kV.

Thus, although the beam power is higher, the e-beam welder's beam energy is lower by a factor of 20. The beam from the multifrequency gun **100** should therefore penetrate more deeply into the material, and should almost certainly be able to provide higher-precision, smaller-area welds.

[0075] It should be understood that the beam power, 700 W, can easily be provided for by relatively compact, CW RF power sources. This would result in an e-beam welder that is smaller and more compact, due to the elimination of need for high-voltage DC power supplies.

[0076] Also if the cathode radius were to be doubled, to 0.2 mm, and the beam current increased by an order of magnitude, to 5 mA, the final energy spread remains approximately the same at $1.8 \cdot 10^{-4}$, and the emittance increases to $2.6 \cdot 10^{-2} \mu\text{m}$, roughly in proportion to the electron beam current. The beam power increases to 7 kW.

[0077] The penetration of an electron beam into matter scales (at low energies) approximately as:

$$\delta z \approx 0.1 \cdot E^{1.5} / \rho \tag{2}$$

where δz is the penetration depth in μm , E is the beam energy in kV, and ρ is the material density in g/cm^3 . This is an empirical formula, but is in reasonable agreement with theoretical calculations. For instance, a 15 kV electron beam should penetrate about $2.3 \mu\text{m}$ into a silicate material with a density of $2.5 \text{ g}/\text{cm}^3$.

[0078] Given a notional 100 kV beam energy for an electron microscope, the beam from the FE cathode gun, configured to run with the energy filter and a final beam energy of 1.7 MeV, could be expected to penetrate approximately 70 times as deeply into a sample, all other things being equal.

[0079] For a typical electron beam welder operating at 60 kV, the expected penetration depth into iron or copper would be around $5.5 \mu\text{m}$. (Actual welds can go much deeper due to heat diffusion etc.) The beam from the FE cathode gun without the energy filter, with a final beam energy of 1.4 MeV, should penetrate 0.6 mm, more than 100 times as deep, and therefore depositing more of the electron beam energy into the volume of the metal as opposed to on the surface.

[0080] In brief, the disclosed method for gating the emission from a field-emission cathode makes the FE cathode a viable choice for high-brightness RF electron gun design. The beam quality is improved via standard post-gun manipulations. Performance figures were calculated for an electron microscope; the results also indicate that a compact, precision electron-beam welder can be constructed using an almost identical beamline.

[0081] Also when superconducting cavities are used for the gun and linearizer cavities, there is effectively no power lost in the cavity walls and the RF power system can consist of relatively low-power, compact oscillator sources. This would maintain a relatively compact footprint for an electron microscope device, and should potentially reduce the footprint for an electron-beam welder.

[0082] Other applications of interest include the use of the gun and linearizer to provide beam for a compact free-electron laser operating in the THz region.

[0083] FIG. 11 provides a detail view of a novel cathode **102** that provides a focused electron beam in accordance

with the present invention. Cathode **102** is a planar focusing cathode. The planar focusing cathode includes a selected dielectric material **120**, such as a ceramic material, to provide an electron beam emission surface **130**. A first metal surface **122** and conducting wall **110** respectively are provided both behind and in front of the dielectric material **120** to shape the electric fields that accelerate and guide the beam from the cathode surface **130**. The dielectric material **120** can be penetrated by electric fields, allowing the planar focusing cathode **102** to provide focusing for the electron beam starting at the substantially flat surface **130** of the cathode dielectric material **120**. The first metal surface or shorting plunger **122** behind the dielectric material **120** is slidingly positioned in a cavity or vacuum **124** relative to the dielectric material **120**. The distance between the shorting plunger **122** and the dielectric material **120** determines the effective focusing force applied to an electrode beam, for example, as illustrated in FIG. 13

[0084] FIG. 12 illustrates exemplary electric field contours of the planar focusing cathode **1100** of FIG. 11 in accordance with the present invention.

[0085] FIG. 13 illustrates an exemplary normalized radial electric field at the cathode surface of the planar focusing cathode of FIG. 11 in accordance with the present invention.

[0086] In FIG. 13 a radial electric field at the cathode surface is shown that is normalized to the longitudinal field, as a function of radius, for three different positions of the plunger **122**.

[0087] While the present invention has been described with reference to the details of the embodiments of the invention shown in the drawing, these details are not intended to limit the scope of the invention as claimed in the appended claims.

1-5. (canceled)

6. A planar focusing cathode for providing a focused electron beam comprising:

- a selected dielectric material for providing an electron beam emission surface; said electron beam emission surface including a substantially flat surface;
- a first metal surface behind said dielectric material;
- a second metal surface radially surrounding said dielectric material; said first metal surface and said second metal surface for shaping electric fields that accelerate and guide an electron beam from the electron beam emission surface;

said dielectric material being penetrated by electric fields and allowing the planar focusing cathode to provide focusing of said electron beam starting at said substantially flat surface of the cathode dielectric material.

7. A planar focusing cathode as recited in claim 6 wherein said first metal surface is slidingly received in a cavity behind said dielectric material and is positioned to provide focusing of said electron beam.

8. A planar focusing cathode as recited in claim 6 wherein selected dielectric material includes a ceramic material.

9. A planar focusing cathode as recited in claim 6 wherein selected dielectric material functions as a cathode of a high brightness RF electron gun.

10. A planar focusing cathode as recited in claim 6 wherein selected dielectric material provides focusing of said electron beam, and the need for magnetic lenses including solenoids between an electron gun and a following accelerator section are eliminated.

11. A planar focusing cathode as recited in claim 6 wherein selected dielectric material provides focusing of said electron beam, and the need for a curved cathode surface is eliminated.

* * * * *